

Manual 1

Mounting Profile

The CurveSign system is designed on the basis of a vertical module measuring 17 mm.

The vertical spacing between two signs is 3 mm.

Therefore the following applies for each sign:

Height = height of module - 3

Height = $2 \times 17 - 3 = 31$

Height = $3 \times 17 - 3 = 48$

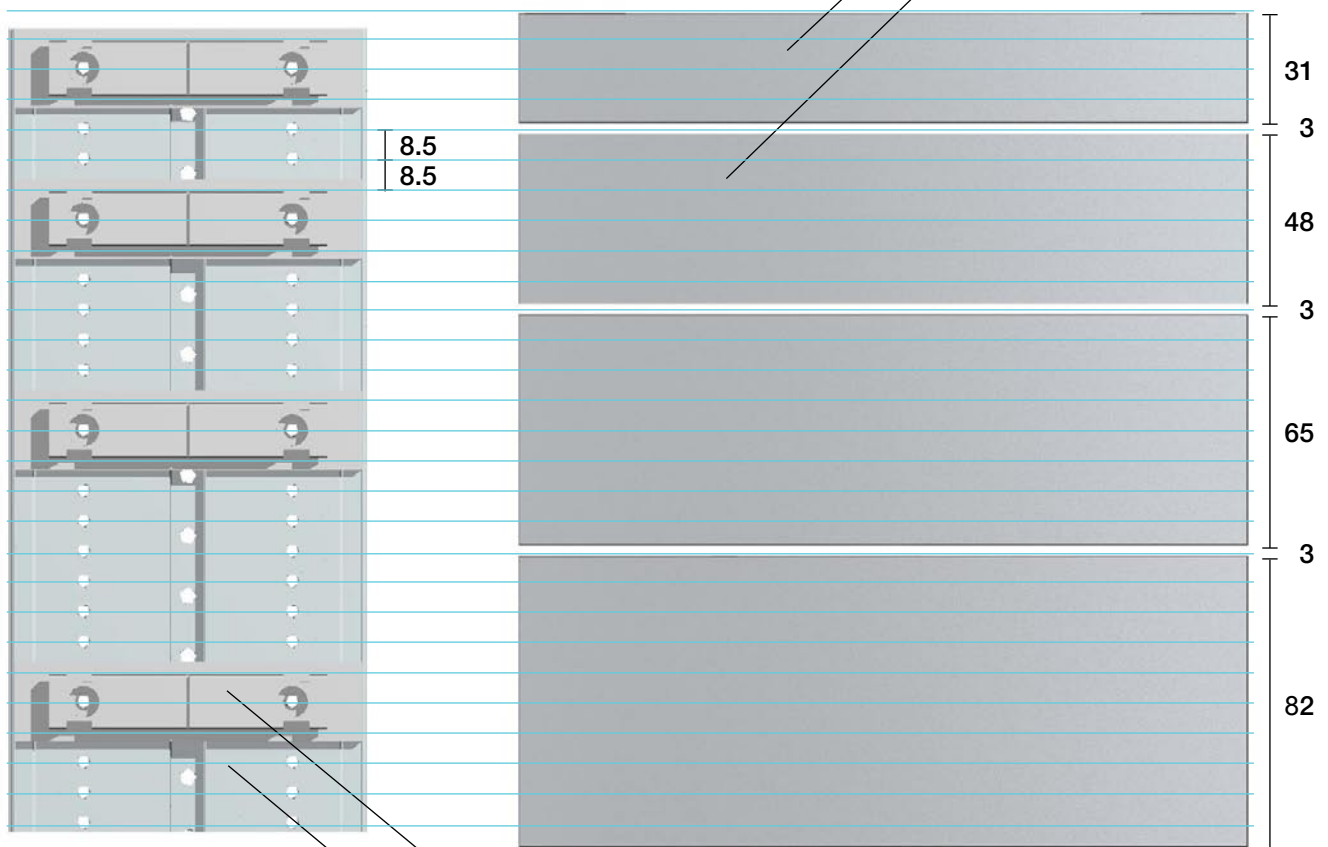

When signs are mounted in a group, they are mounted on an aluminium profile. Two columns of holes are punched in the mounting profile for attachment of mountings on the back of each sign.

Mounting

Mounting profile

Hole spacing = 8.5 mm
= 1/2 module

Manual 2

Mounting Profile for Wall Signs 150 / 210 mm

Mountings for single signs are attached directly to the wall by screws.

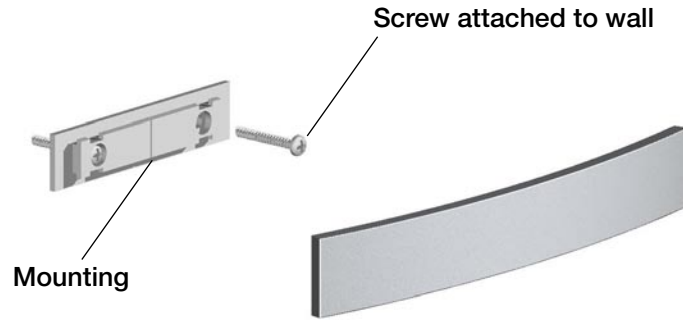

Mountings for a group of signs are attached to a mounting profile.

How to calculate mounting profile height:

Total number of sign heights = mm

Number of spacings x 3 mm = mm

Total height less 10 mm.

The mounting profile is attached to the wall by screws in the centreline of the profile.

Mountings are attached using plastic pinol screws that are pressed through the holes in the mounting into the mounting profile with a special purpose tool.

Spaceblocks are pressed into the mounting profile opposite the gaps between the signs.

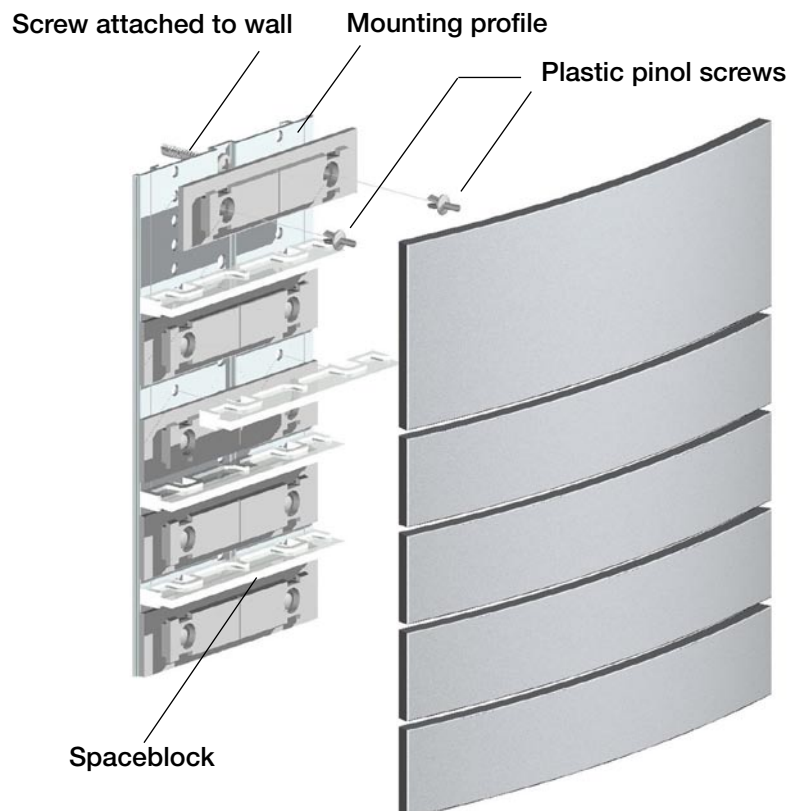

Manual 3

Mounting profile for Wall Signs 390 / 600 mm

For wide signs supporting profiles are used, and together with the mounting profile they form a stable base for the signs.

The supporting profiles and the mounting profile are assembled by bringing the profiles into engagement with each other. The mounting profile is attached to the wall by screws in the profile centreline. The supporting profiles are fixed against the wall by friction alone.

How to calculate mounting profile height:

Total number of sign heights = mm

Number of spacings x 3 mm = mm

Total height less 10 mm.

Mountings are attached by plastic pinol screws.

Spaceblocks are pressed into the mounting profile opposite the gaps between the signs.

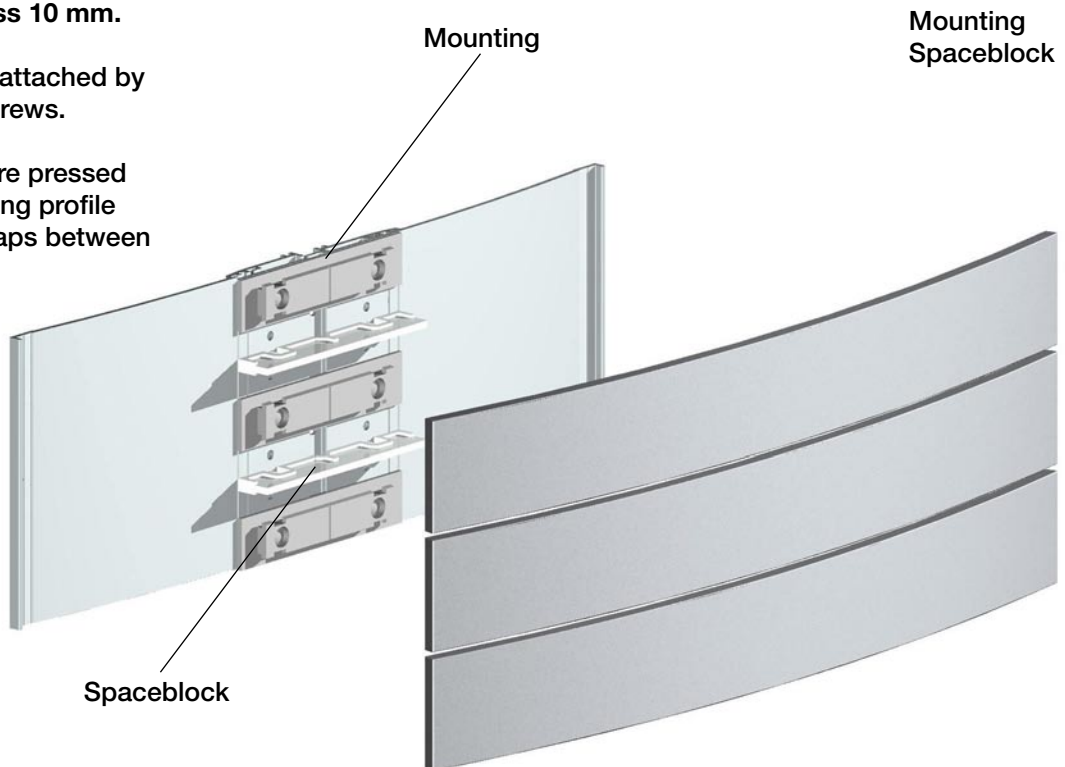
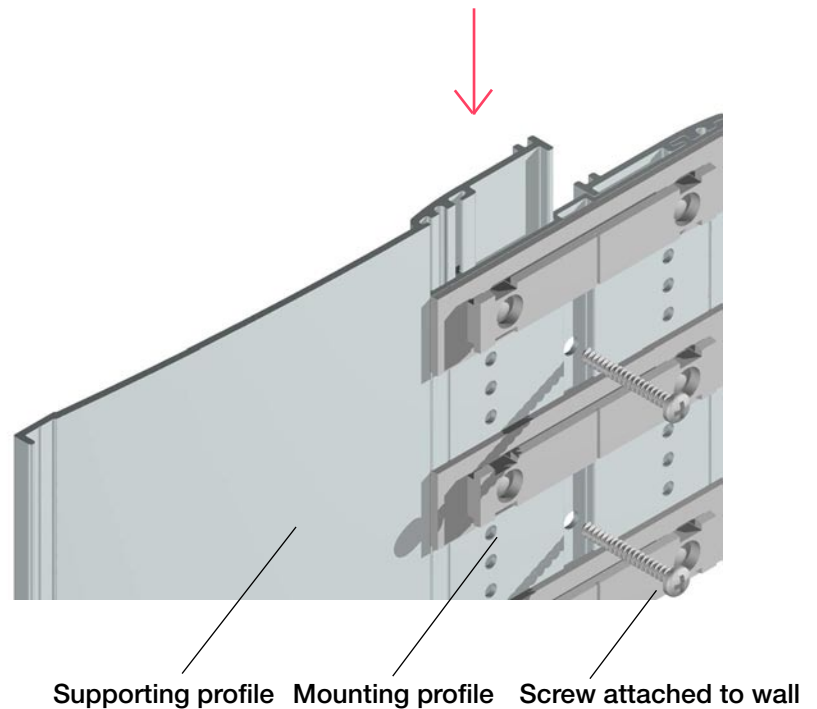

Manual 4

**Mounting Profile for
Projecting Signs 150 / 210 mm**

Projecting profiles 150 and 210 mm are used to support projecting signs.

Projecting profile height has to be 9 mm less than sign height.

Mountings are attached with self-tapping screws in the middle of the projecting profiles' raised ribs.

On projecting profile 150 mm each mounting is attached by a screw at the end closest to the wall, while the other end of the mounting is attached by a strip of double-sided tape.

On projecting profile 210 mm each mounting is attached by two screws.

Plastic sign lids are retained in position and supported by the inner edges of the signs.

Wooden sign lids are supported directly by the projecting profile.

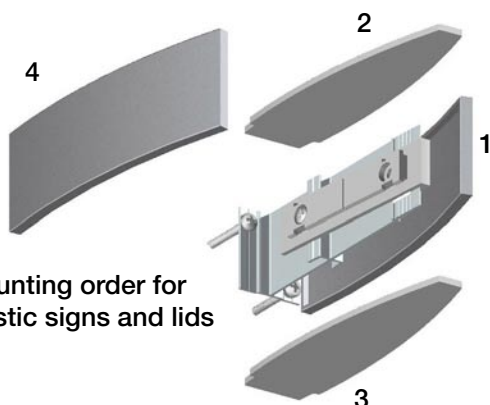
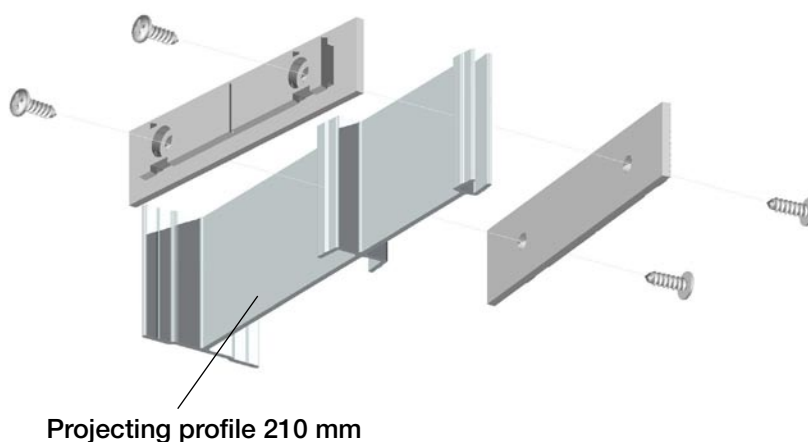
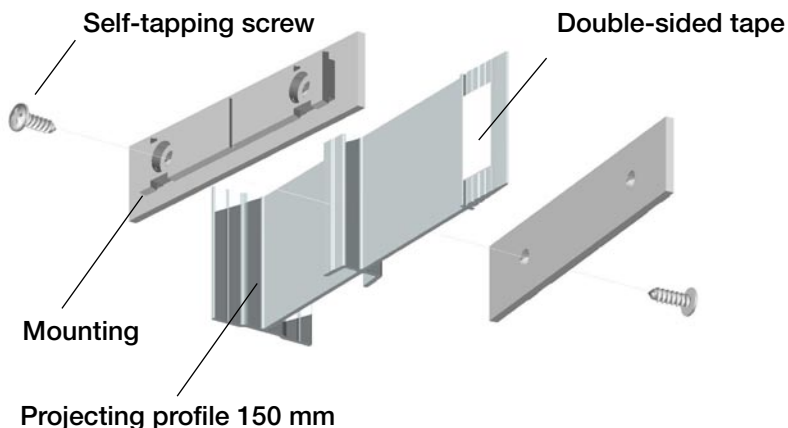

Mounting order for plastic signs and lids

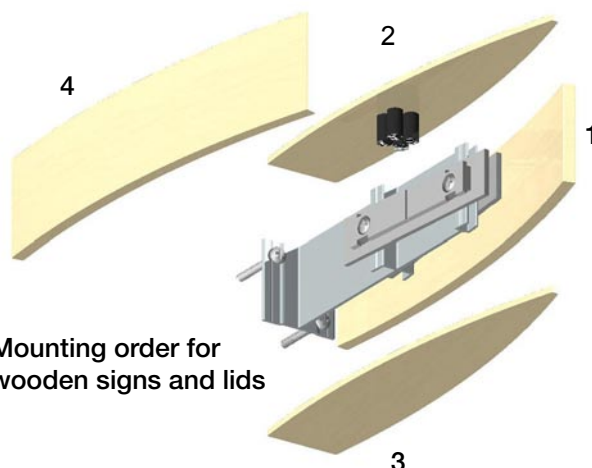

Mounting order for wooden signs and lids

Manual 5

**Mounting Profile for
Suspended Signs 390 / 600 mm**

Suspended signs are attached to a base of two mounting profiles and two suspended profiles. Suspended profile height and mounting profile height are equal. The profiles are attached to each other and locked by a few self-tapping screws.

How to calculate mounting profile height:

Total number of sign heights = mm

Number of spacings x 3 mm = mm

Total height less 10 mm.

The signs are suspended from 2 wires (approx. Ø1.0 mm). Pendant tubes may be mounted on the wires if required.

Each wire end is closed by a seal. A M6 thread is cut into the screw groove. The wire including the seal is lowered as a bow into the inner groove, and a M6 tailstock is screwed down into the groove beside the wire. The wire is held in position by the tailstock, preventing the seal from moving past. **Please note that the tailstock may be used for fine adjustment of the height.**

Mountings are attached by plastic pinol screws.

Spaceblocks are pressed into the mounting profile opposite the gaps between the signs.

Bottom lid are attached by plastic pinol screws.

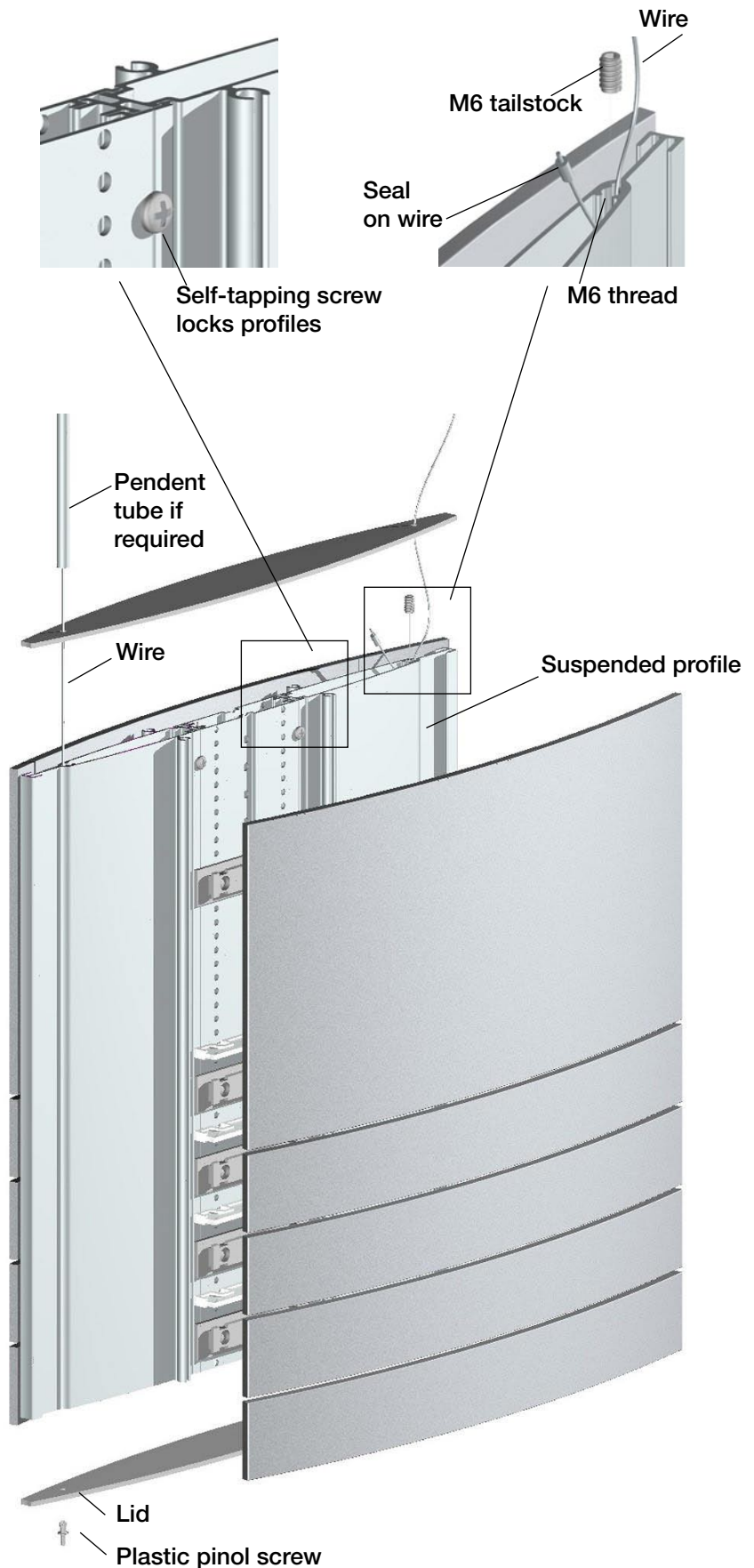

Manual 6

Mounting Profile for Standing Pylons 390 / 600 mm.

Standing pylons are mounted in the same way as suspended, except for the top wires and the bottom lid.

The pylon is attached to a 10 mm oval-shaped steel plate. Attachment is made by the mounting profiles 6 attachment holes.

The oval-shaped steel plate has 6 pre-drilled holes 8 mm in diameter, countersinking 12 mm.

Base plate formats:

For pylon width 390 mm:
215 x 490 mm.

For pylon width 600 mm:
310 x 700 mm.

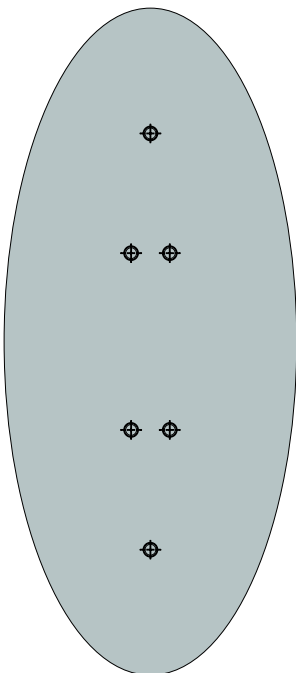

Base plate

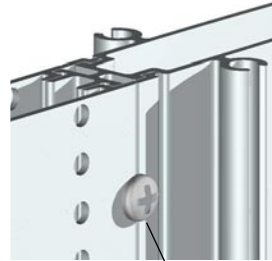

Self-tapping screw locks profiles



Pylon profile